

SNAPTIE SYSTEM

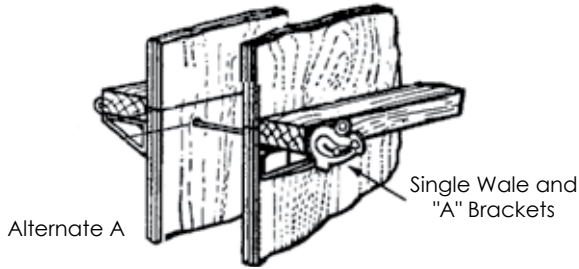

VERTICAL FORMING SYSTEMS

Jahn® Forming System (cont)



Joint Cover Details:

Alternate A - Drill 9/16" diameter hole 1 1/8" down from top edge of the lower sheet of plywood. Install snap tie, "A" Brackets and wale and then the upper sheet of plywood. Nail the upper sheet of plywood to the wale.

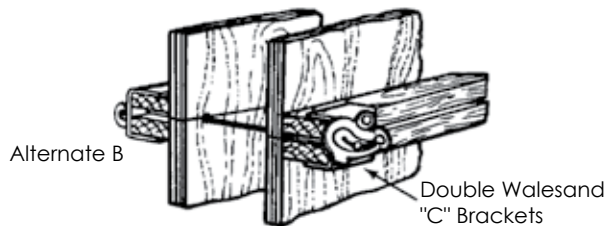

Alternate B - Install snap tie in the joint between the panels. Add double wales and a "C" Bracket.

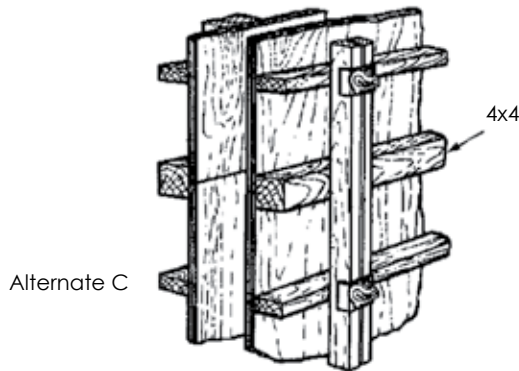

Alternate C - Nail 4x4 wale to lower sheet of plywood, hold the wale in place with strongbacks and add upper sheet of plywood

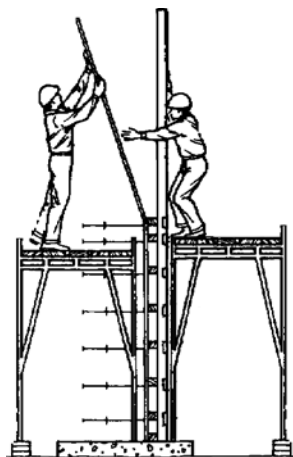

Installation Of Second Lift Of Plywood:

Lift the plywood sheet and place it into position. Hold the sheet in place with a short 2x4 spacing block, snap tie and "C" Bracket placed toward the top of the panel and nail the bottom of the sheet to the joint cover wale.

Set additional panels by nailing them to the joint cover wale and securing them to the previous panel with a small wood cleat.

Install the snapties, brackets and wales - working bottom to top.

Note: Snap ties are not designed to carry scaffold bracket loads.